

EUROSWIM



TECHNICAL DATA

Applications

High efficiency self-priming centrifugal pumps with built-in large capacity prefilter. **Completely watertight motor**. Extremely **quiet running** and **great reliability**, developed for water circulation and filtration in domestic and residential swimming pools. Suitable also for special applications that call for handling of aggressive liquids, in fish farms, agriculture and industry.

Pump construction features

Pump body in fibreglass reinforced technopolymer. Strainer cover in clear antioxidant polycarbonate to guarantee constant visibility through time. Nylon strainer. Impeller in fibreglass-reinforced technopolymer developed to ensure total coverage and isolation of the motor shaft from the pumped liquid. Diffuser in reinforced technopolymer. Mechanical seal in carbon / alumina / NBR / AISI 316. Pump body O-rings in NBR, threaded fasteners and reinforcing rings in AISI 316. Butterfly filler and drain plugs that can be removed and refitted without tools.

Motor construction characteristics

Asynchronous continuous duty 2-pole motor (S1) with generous range of power ratings from 0.5 HP to 3 HP, single phase and three-phase (see technical specifications).

Motor casing in die cast aluminium with electrophoresic surface treatment to prevent oxidation even in aggressive environmental conditions. Baseplate supplied as standard with rubber mounts to reduce vibration transmission.

Single phase version with integral thermal and overcurrent protection and permanent split capacitor (PSC), assembled inside the terminal box for all versions.

Motor and terminal box protection rating: IP55

Insulation class: F

Ball bearings: water-proof, sealed, resistant to water and humidity.

Motor construction to EN 60335-2-41 standards

Standard voltage: Single phase 220-240V 50Hz

Three-phase 230/400V 50Hz

TECHNICAL DATA

Operating range: up to 42 m³/h with pressure head of up to 22 m
 Pumped liquid: clean water or slightly contaminated with suspended solid debris, highly aggressive water with high percentage of chlorine/bromine and PHMB (Polyhexamethylene biguanide) or water treated with the chlorine electrolysis process.
 long fibre;
 PH range: 6.5 – 8.4
 Liquid temperature range: up to 60°C
 Maximum ambient temperature : 50°C
 Maximum working pressure: 2.5 Bar
 Nominal working pressure: 0.8 - 1.2 bar (ideally 1 bar)
 Installation: fixed or portable in horizontal position
 Special executions on request: other voltages and/or frequencies.
 Fittings on request: kit 2"/50 - 63 (two fittings + O-ring - see "Accessories")
 Reference standard: IEC – 60364

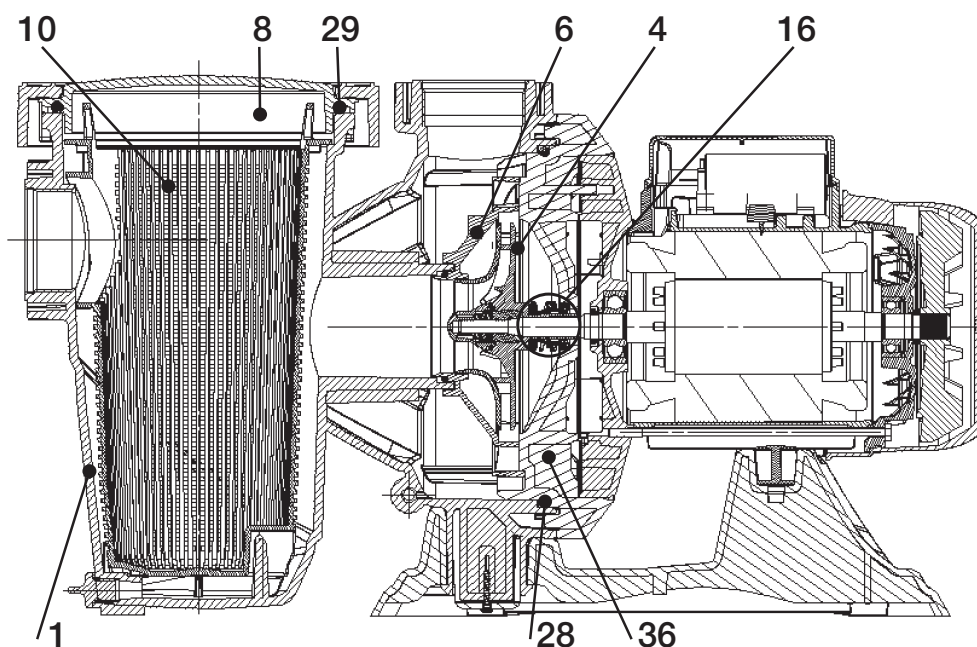

N	PART (*)	MATERIAL
1	PUMP CASING	REINFORCED TECHNOPYLIMER
4	IMPELLER	REINFORCED TECHNOPYLIMER
6	DIFFUSER	REINFORCED TECHNOPYLIMER
8	STRAINER COVER	POLYCARBONATE
10	FILTER	TECNOPYLIMER
16	MECHANICAL SEAL	CARBON / ALUMINA / NBR / AISI 316
28	O-RING	NBR
29	O-RING	NBR
36	SEAL CARRIER DISC	REINFORCED AND STABILISED TECHNOPYLIMER

*TO CONTACT WITH THE LIQUID

The performance curves are based on kinematic viscosity values = 1 mm²/s and density equivalent to 1000 kg/m³. Tolerance of curves to ISO 9906.
 Liquid temperature range: from 0°C to 60°C
 Maximum ambient temperature: +50°C

EUROSWIM 50

HYDRAULIC DATA

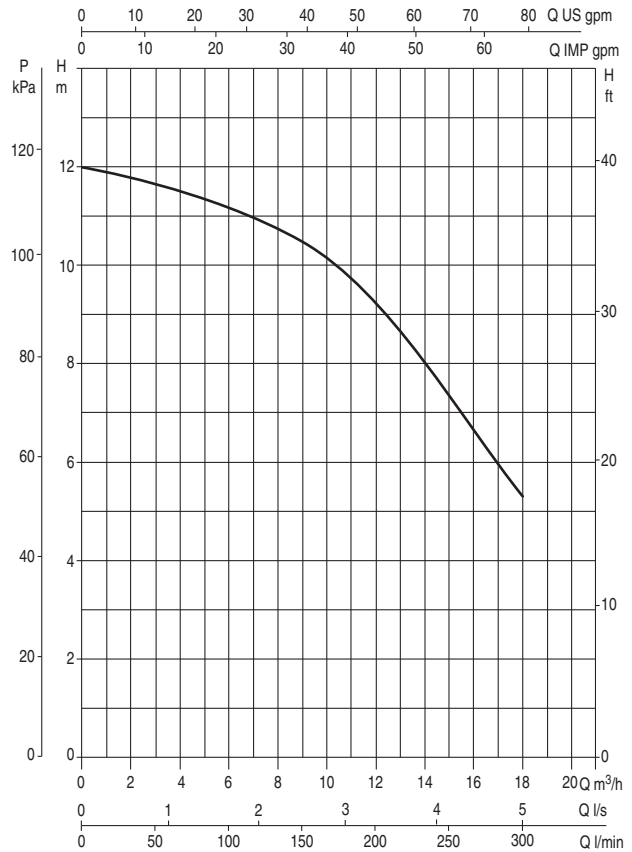
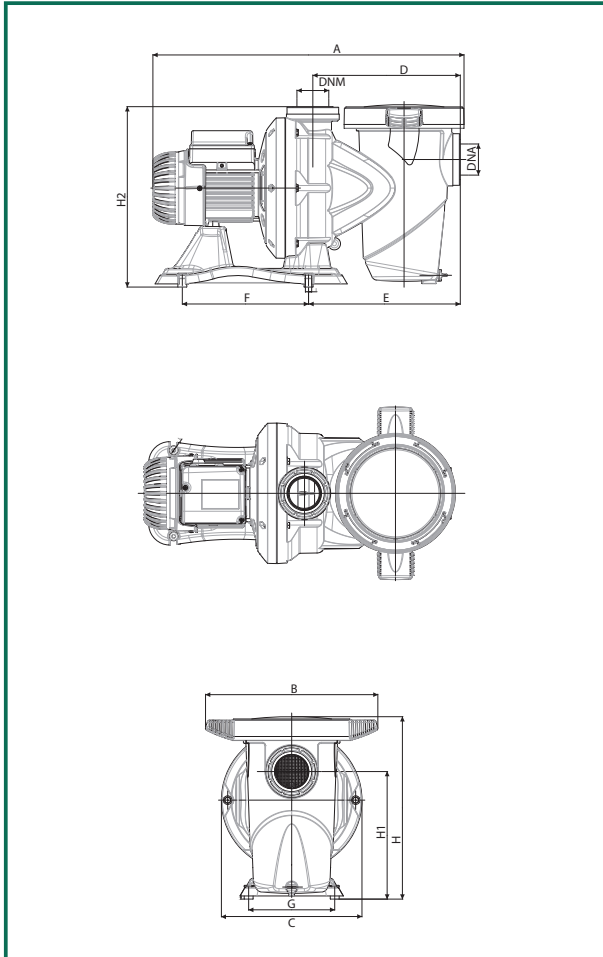

DIMENSIONS AND WEIGHTS

MODEL	A	B	C	D	E	F	G	H	H1	H2	I	L	DNA	DNM	NO. PIECES PALLET	DIMENSION PACKING			VOLUME m ³	GROSS WEIGHT Kg
																L/A	L/B	H		
EUROSWIM 50 M	542	300	245	257	265	220	150	317	222	314	11	6,5	G2"	G2"	8	600	360	400	0,09	11,1

ELECTRICAL DATA

MODEL	ELECTRICAL DATA								NOISE LEVEL dB (A)	Q m ³ /h l/min	HYDRAULIC DATA					
	SUPPLY VOLTAGE 50 Hz	P1 MAX W	P2 NOMINAL		In A	CAPACITOR		0			3	6	9	12	18	
			kW	HP		μF	Vc									0
EUROSWIM 50 M	1x220-240 V ~	900	0,33	0,5	4,2	16	450	53	H (m)	12,0	11,7	11,2	10,5	9,3	5,3	

The performance curves are based on kinematic viscosity values = 1 mm²/s and density equivalent to 1000 kg/m³. Tolerance of curves to ISO?9906.
 Liquid temperature range: from 0°C to 60°C
 Maximum ambient temperature: +50°C

EUROSWIM 75

HYDRAULIC DATA

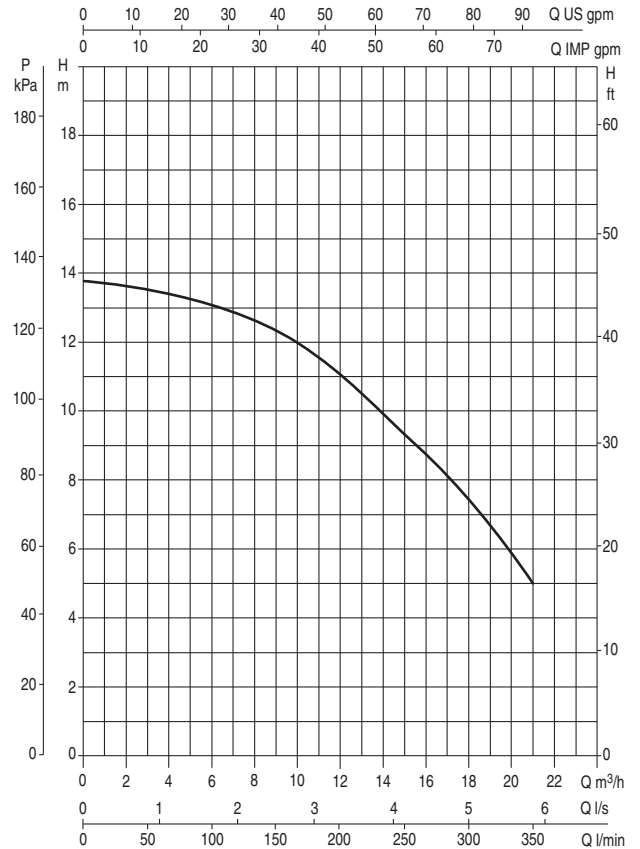
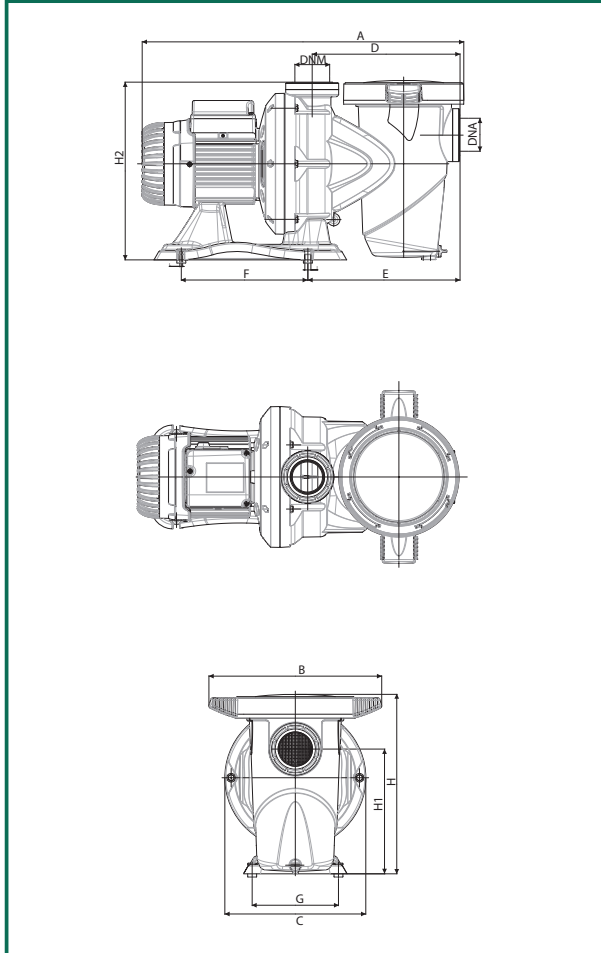

DIMENSIONS AND WEIGHTS

MODEL	A	B	C	D	E	F	G	H	H1	H2	I	L	DNA	DNM	NO. PIECES PALLET	DIMENSION PACKING			VOLUME m ³	GROSS WEIGHT Kg
																L/A	L/B	H		
EUROSWIM 75 M	559	300	245	257	265	220	150	317	222	314	11	6,5	G2"	G2"	8	600	360	400	0,09	12,1
EUROSWIM 75 T	559	300	245	257	265	220	150	317	222	314	11	6,5	G2"	G2"	8	600	360	400	0,09	12,1

ELECTRICAL DATA

MODEL	ELECTRICAL DATA							NOISE LEVEL dB (A)	Q m ³ /h l/min	HYDRAULIC DATA						
	SUPPLY VOLTAGE 50 Hz	P1 MAX W	P2 NOMINAL		In A	CAPACITOR										
			kW	HP		μF	Vc			0	3	6	9	12	18	21
EUROSWIM 75 M	1x220-240 V ~	1000	0,5	0,75	5	20	450	56	H (m)	13,8	13,5	13,1	12,4	11,1	7,5	5
EUROSWIM 75 T	3x230-400 V ~	950	0,5	0,75	3,5 / 2	-	-	56		13,8	13,5	13,1	12,4	11,1	7,5	5

The performance curves are based on kinematic viscosity values = 1 mm²/s and density equivalent to 1000 kg/m³. Tolerance of curves to ISO 9906.
 Liquid temperature range: from 0°C to 60°C
 Maximum ambient temperature: +50°C

EUROSWIM 100

HYDRAULIC DATA

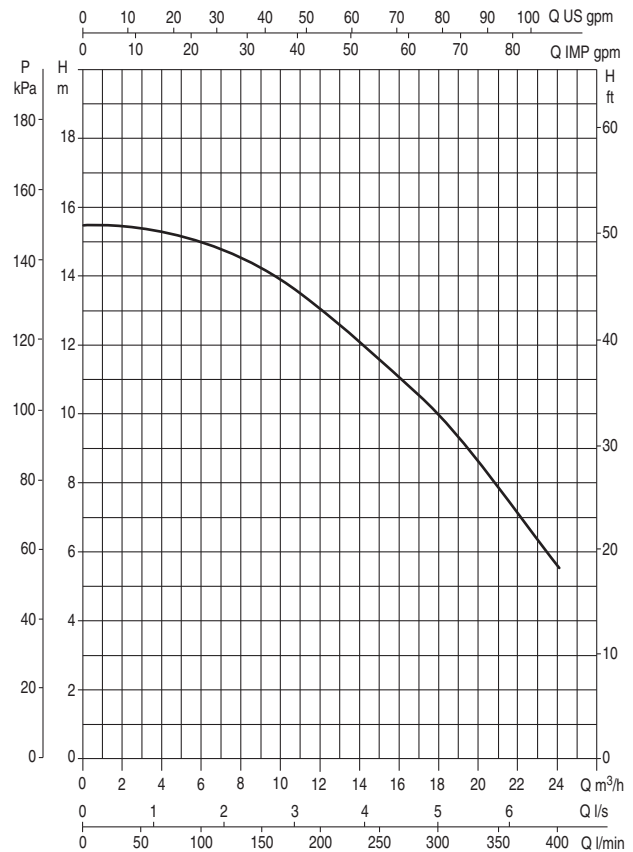
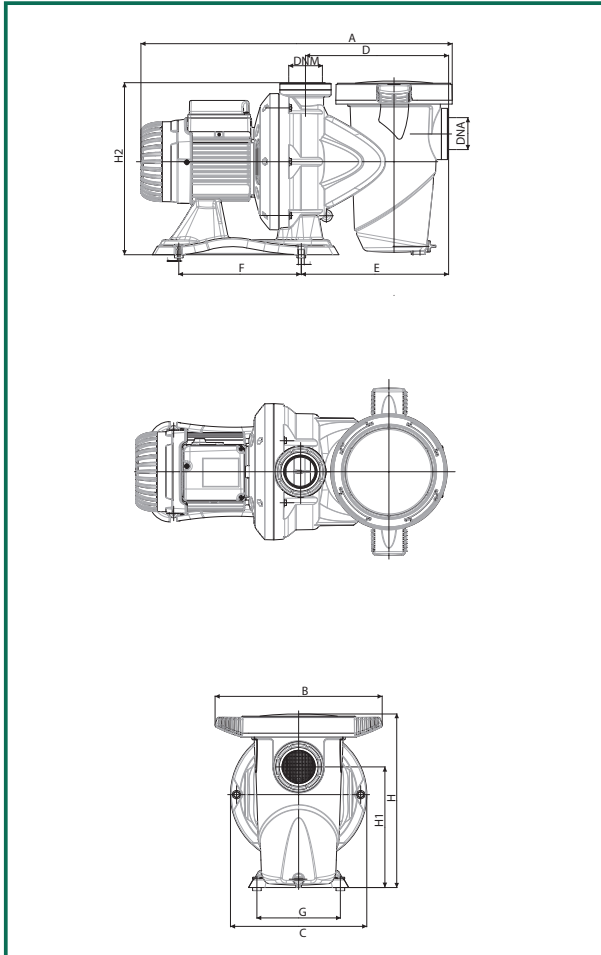

DIMENSIONS AND WEIGHTS

MODEL	A	B	C	D	E	F	G	H	H1	H2	I	L	DNM	DNM1	NO. PIECES PALLET	DIMENSION PACKING			VOLUME m ³	GROSS WEIGHT Kg
																L/A	L/B	H		
EUROSWIM 100 M	559	300	245	257	265	220	150	317	222	314	11	6,5	G2"	G2"	8	600	360	400	0,09	13,8
EUROSWIM 100 T	559	300	245	257	265	220	150	317	222	314	11	6,5	G2"	G2"	8	600	360	400	0,09	13,8

ELECTRICAL DATA

MODEL	ELECTRICAL DATA							NOISE LEVEL dB (A)	Q m ³ /h l/min	HYDRAULIC DATA								
	SUPPLY VOLTAGE 50 Hz	P1 MAX W	P2 NOMINAL kW	P2 NOMINAL HP	In A	CAPACITOR				H (m)	0	3	6	9	12	18	21	24
						μF	Vc				0	50	100	150	200	300	350	400
EUROSWIM 100 M	1x220-240 V ~	1300	0,75	1	6,3	25	450	57	15,4	15,4	15	14,2	13,1	10,0	7,8	5,6		
EUROSWIM 100 T	3x230-400 V ~	1200	0,75	1	4 / 2,4	-	-	57	15,4	15,4	15	14,2	13,1	10,0	7,8	5,6		

The performance curves are based on kinematic viscosity values = 1 mm²/s and density equivalent to 1000 kg/m³. Tolerance of curves to ISO 9906.
 Liquid temperature range: from 0°C to 60°C
 Maximum ambient temperature: +50°C

EUROSWIM 150

HYDRAULIC DATA

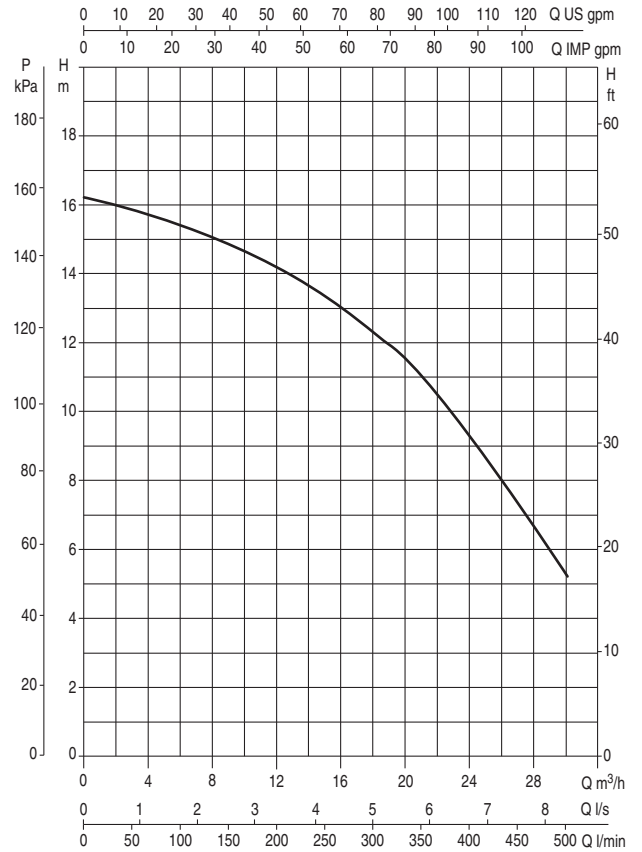
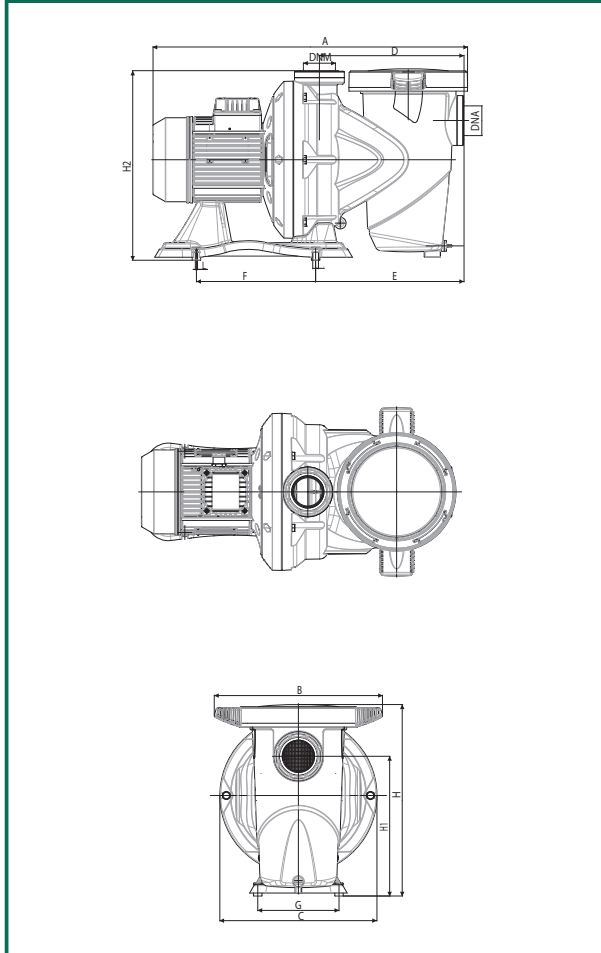

DIMENSIONS AND WEIGHTS

MODEL	A	B	C	D	E	F	G	H	H1	H2	I	L	DNA	DNM	NO. PIECES PALLET	DIMENSION PACKING			VOLUME m ³	GROSS WEIGHT Kg
	L/A	L/B	H																	
EUROSWIM 150 M	581	311	290	267	274	220	150	353	258	350	11	6,5	G2"	G2"	8	600	360	400	0,09	17,9
EUROSWIM 150 T	581	311	290	267	274	220	150	353	258	350	11	6,5	G2"	G2"	8	600	360	400	0,09	16,7

ELECTRICAL DATA

MODEL	ELECTRICAL DATA						NOISE LEVEL dB (A)	Q m ³ /h l/min	HYDRAULIC DATA																		
	SUPPLY VOLTAGE 50 Hz	P1 MAX W	P2 NOMINAL		In A	CAPACITOR																					
			kW	HP		μF			Vc	0	3	6	9	12	18	21	24	30									
EUROSWIM 150 M	1x220-240 V ~	1600	1,1	1,5	7	31,5	450	59	H (m)	16,2	15,9	15,4	14,9	14,2	12,4	11,1	9,3	5,3									
EUROSWIM 150 T	3x230-400 V ~	1500	1,1	1,5	5 / 2,9	-	-	59		16,2	15,6	15,2	14,6	13,9	12,4	11,1	9,3	5,3									

The performance curves are based on kinematic viscosity values = 1 mm²/s and density equivalent to 1000 kg/m³. Tolerance of curves to ISO 9906.
 Liquid temperature range: from 0°C to 60°C
 Maximum ambient temperature: +50°C

EUROSWIM 200

HYDRAULIC DATA

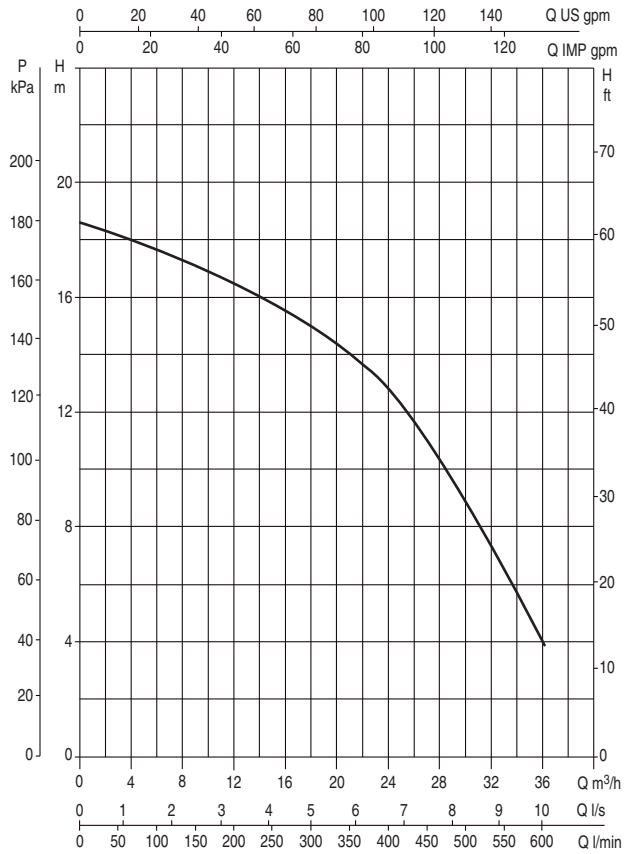
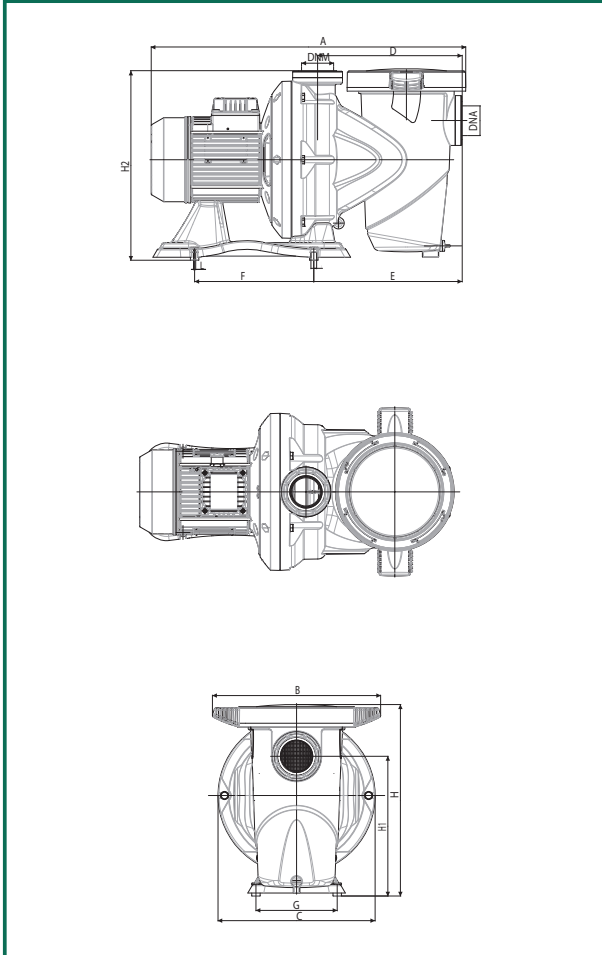

DIMENSIONS AND WEIGHTS

MODEL	A	B	C	D	E	F	G	H	H1	H2	I	L	D _{NA}	D _{NM}	NO. PIECES PALLET	DIMENSION PACKING			VOLUME m ³	GROSS WEIGHT Kg
																L/A	L/B	H		
EUROSWIM 200 M	655	311	290	267	274	220	150	353	258	350	11	6,5	G2"	G2"	6	720	350	430	0,11	20
EUROSWIM 200 T	581	311	290	267	274	220	150	353	258	350	11	6,5	G2"	G2"	6	720	350	430	0,11	17,6

ELECTRICAL DATA

MODEL	ELECTRICAL DATA							NOISE LEVEL dB (A)	Q m ³ /h l/min	HYDRAULIC DATA									
	SUPPLY VOLTAGE 50 Hz	P1 MAX W	P2 NOMINAL		I _n A	CAPACITOR													
			kW	HP		μF	Vc			0	3	6	9	12	18	21	24	30	36
EUROSWIM 200 M	1x220-240 V ~	1900	1,5	2	8,6	40	450	62	H (m)	18,6	18,2	17,7	17,1	16,5	15,0	14,1	12,8	9,0	4
EUROSWIM 200 T	3x230-400 V ~	1900	1,5	2	6 / 3,5	-	-	62		18,6	18,2	17,7	17,1	16,5	15,0	14,1	12,8	9,0	4

The performance curves are based on kinematic viscosity values = 1 mm²/s and density equivalent to 1000 kg/m³. Tolerance of curves to ISO 9906.
 Liquid temperature range: from 0°C to 60°C
 Maximum ambient temperature: +50°C

EUROSWIM 300

HYDRAULIC DATA

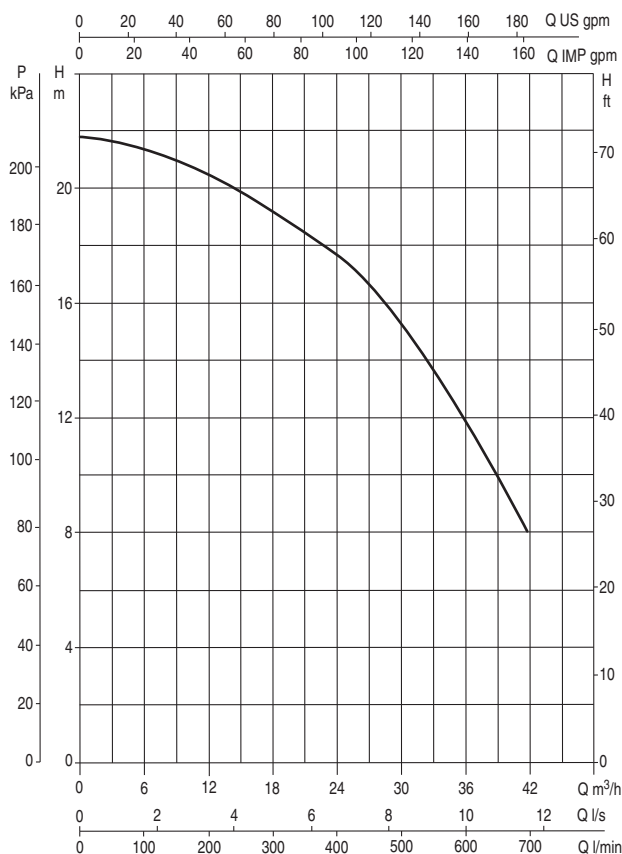
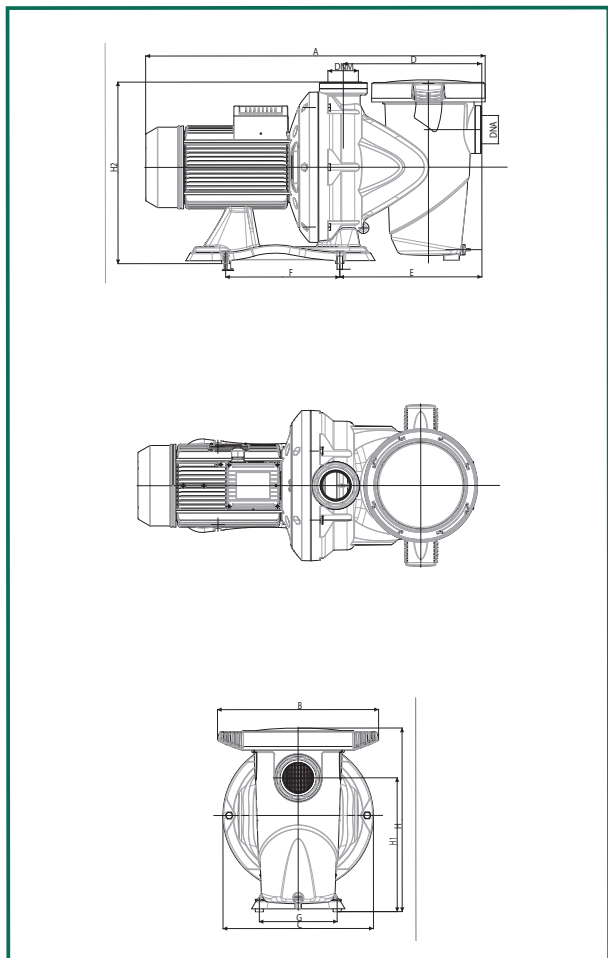

DIMENSIONS AND WEIGHTS

MODEL	A	B	C	D	E	F	G	H	H1	H2	I	L	DnA	DnM	NO. PIECES PALLET	DIMENSION PACKING			VOLUME m ³	GROSS WEIGHT Kg
																L/A	L/B	H		
EUROSWIM 300 M	648	252	290	267	274	220	150	387	258	350	11	6,5	G2"	G2"	6	720	350	430	0,11	23,9
EUROSWIM 300 T	648	252	290	267	274	220	150	387	258	350	11	6,5	G2"	G2"	6	720	350	430	0,11	19,9

ELECTRICAL DATA

MODEL	ELECTRICAL DATA							NOISE LEVEL MAX dB (A)	Q m ³ /h l/min	HYDRAULIC DATA										
	POWER SUPPLY 50 Hz	P1 MAX W	P2 NOMINAL		In A	CAPACITOR				H (m)										
			kW	HP		μF	Vc			0	3	6	9	12	18	21	24	30	36	42
EUROSWIM 300 M	1x220-240 V ~	2800	2,2	3	12	40	450	64	H (m)	21,8	21,5	21,3	20,8	20,2	19,2	18,6	17,8	15,3	11,6	7,4
EUROSWIM 300 T	3x230-400 V ~	2800	2,2	3	8,7 / 5	-	-	64	H (m)	21,8	21,5	21,3	20,8	20,2	19,2	18,6	17,8	15,3	11,6	7,4

ACCESSORIES

2" GAS / DN 50-63 CONNECTION FITTINGS KIT

Supplied complete with two items to be fitted on the suction and discharge ports to connect the pump to the system.

The connection with O-ring (towards the pump) is equipped with DN 50 and 63 coupling for greater installation flexibility.

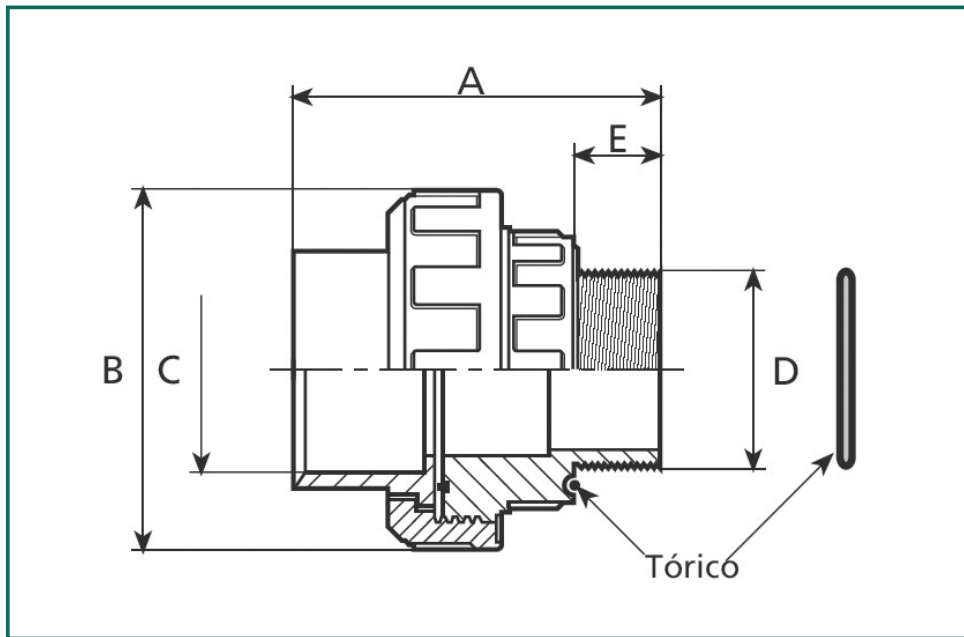

DIMENSIONS AND WEIGHTS

MODEL	A	B	C	D	E	GROSS WEIGHT Kg
2" UNION KIT	99	99	50/63	2"	20	0,7