



STAIRS PUMPS

# General data

CB, CBI

## Applications

- \*Domestic
- \*Liquid transfer and circulation of liquids within light industry and farming
- \*Pressure boosting
- \*Air-conditioning systems
- \*Cooling systems or cooling machine
- \*Specialized OEM equipment

## Pump

The CB and CBI series are non-self priming, horizontal multistage centrifugal pumps. Pump is coupled with motor at the same shaft and mounted on a base-plate. The friendly design makes the pump suitable for installation in the small domestic or industrial water supply systems. The pump is fitted with a mechanical seal and through-going pump-motor shaft.

**CB:** The discharge and suction chamber are made of cast iron. The other parts of pump in contact with the liquid are made of stainless steel. EPDM or Viton O-rings are available as standard.

**CBI:** All parts of pump in contact with the liquid are made of stainless steel. EPDM or Viton O-rings are available as standard.

## Pipe connections:

Connections	CB, CBI 2	CB, CBI 4	CB8	CB12
Suction port	Rp 1	Rp 1 1/4	Rp 1 1/2	Rp 1 1/2
Discharge port	Rp 1	Rp 1	Rp 1 1/4	Rp 1 1/2
Drain hole, priming hole	Rc 3/8	Rc 3/8	Rp 1/2	Rp 1/2

## Motor

The pump is fitted with a totally enclosed, fan-cooled, squirrel-cage motor. Single-phase motors have built-in thermal overload protection. Rated speed: 2850rpm(50Hz), 3450rpm(60Hz)

Enclosure class: IP 54

Insulation class: F

## Standard voltages:

	Phase	voltages
50Hz	1Φ	220-240V
	3Φ	220-240V / 380-415V
60Hz	1Φ	110 / 220V
		220-240V
	3Φ	220-255V / 380-440V
		220-277V / 380-480V

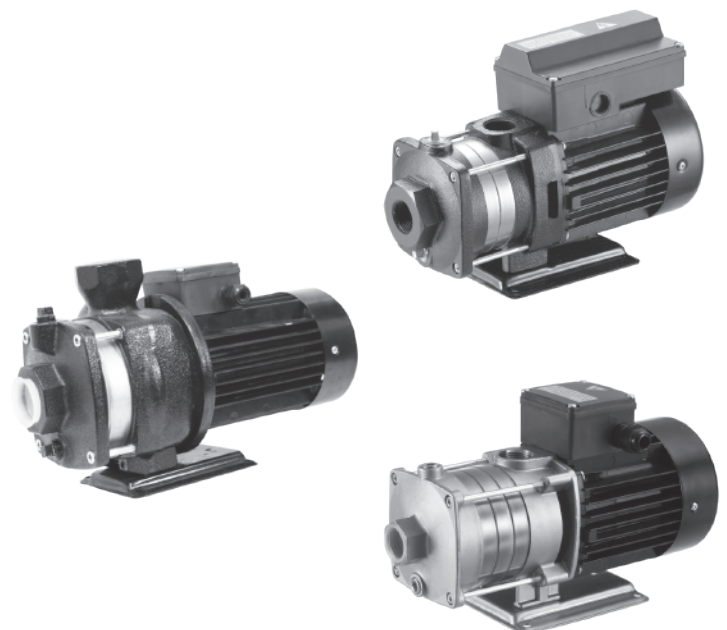

## Operating conditions

Liquid temperature range: 0°C ~+90°C

Maximum ambient temperature: +40°C

Maximum operating pressure: 10 kg /cm<sup>2</sup>.

Maximum inlet pressure is limited by maximum operating pressure.



STAIRS PUMPS

# General data

CB, CBI

## Model code

Type range	Nominal flow rate [m³/h]	Number of stages x10	Mechanical Seals
CB(I) 2 , 4	4	30	CQBE

Type range	Nominal flow rate [m³/h]	Max. discharge pressure[m]	Mechanical Seals
CB(I) 8 , 12	8	30	CQBE

## Operating conditions

Liquid: CB : Thin, clean, non-aggressive and non-explosive liquids without solid particles or fibres.

CBI : Thin, clean, slightly aggressive and non-explosive liquids without solid particles or fibres.

Liquid temperature range: 0°C ~ +90°C.

Maximum ambient temperature: +50°C.

The maximum operating pressure depends on the temperature of the pumped liquid, see table:

Max. operating pressure	10 kg/cm² / bar	6 kg/cm² / bar
CB(I)2, CB(I)4	0°C to + 40°C	+41°C to + 90°C
CB 8, CB12	0°C to + 55°C	+56°C to + 90°C

Min. inlet pressure: According to the NPSH curve + a safety margin of 0.5m.

Max. inlet pressure: Limited by the max. operating pressure.

## Mechanical seals

List of Materials	
Q : Silicon carbide	E : EPDM
U : Tungsten carbide	V : Viton
B : Carbon	C : Seal Type
H : Seal Type	

Mechanical Seals	CB, CBI 2/4	CB 8,12
CQB	●	●
CQQ	Optional	Optional
HUU	Optional	Optional
O-rings		
E	●	●
V	Optional	Optional

● Standard



STAIRS PUMPS

# General data

CB, CBI

## Material construction

CB(I) 2,4

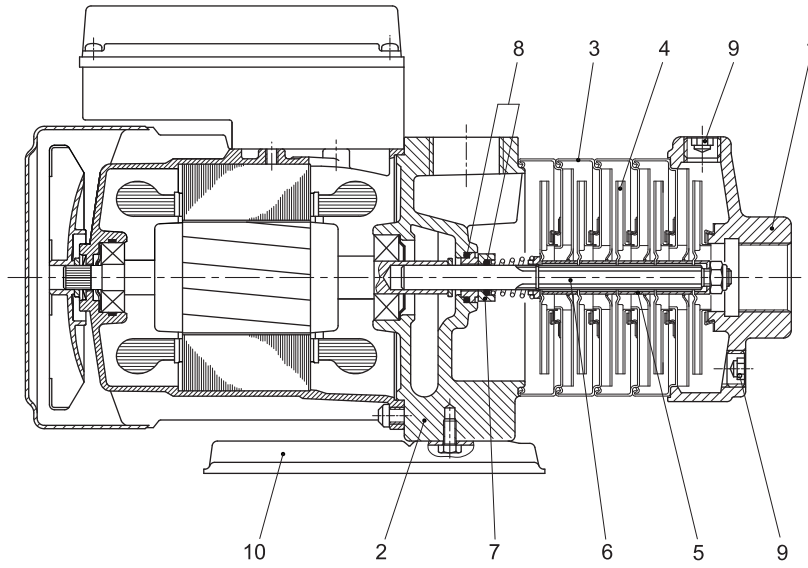

CB 8,12

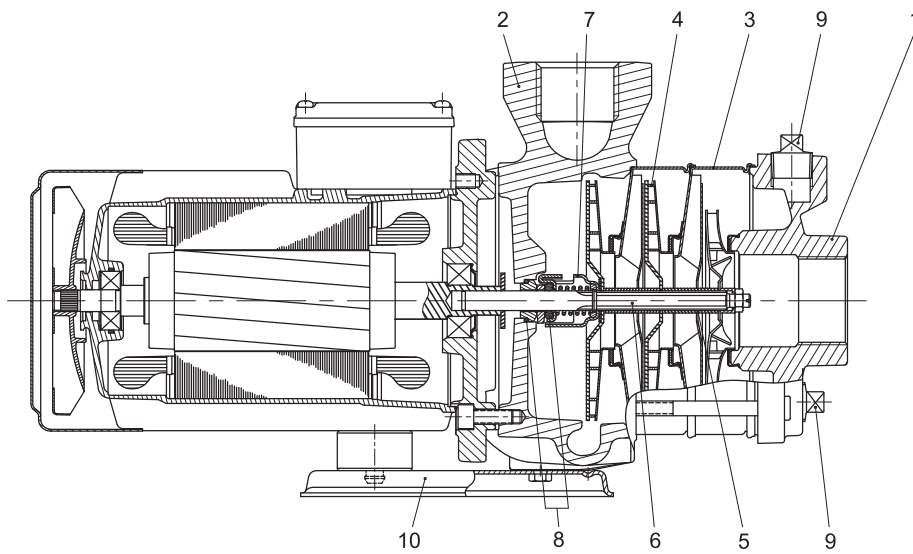

## Materials

Pos.	Description	Materials	
		CB	CBI
1	Suction chamber	Cast iron	SS304
2	Pump head	Cast iron	SS304
3	Intermediate chamber	SS304	SS304
4	Impeller	SS304	SS304
5	Spacing pipe	SS304	SS304
6	Shaft	SS431	SS431
7	Mechanical seal	Silicon carbide / Carbon	Silicon carbide / Carbon
8	O-ring	EPDM	EPDM
9	Drain and priming plug	Steel	SS304
10	Base plate	Steel	SS304



STAIRS PUMPS

# Technical data

CB, CBI 2

## Performance curves 50Hz

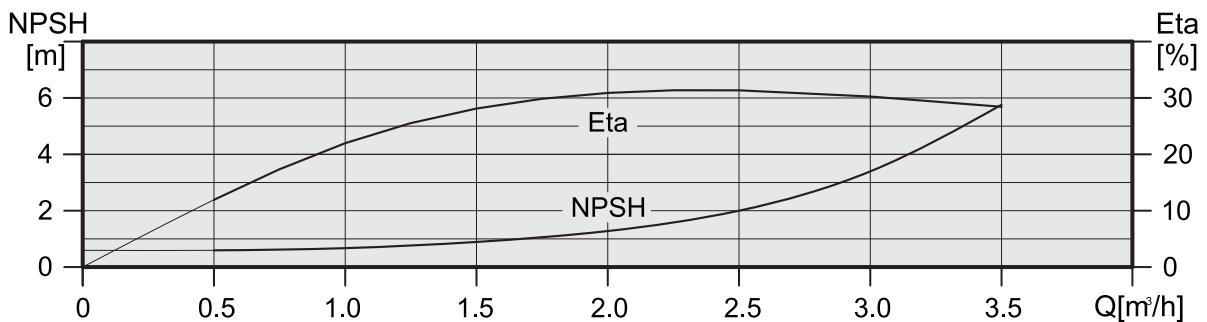
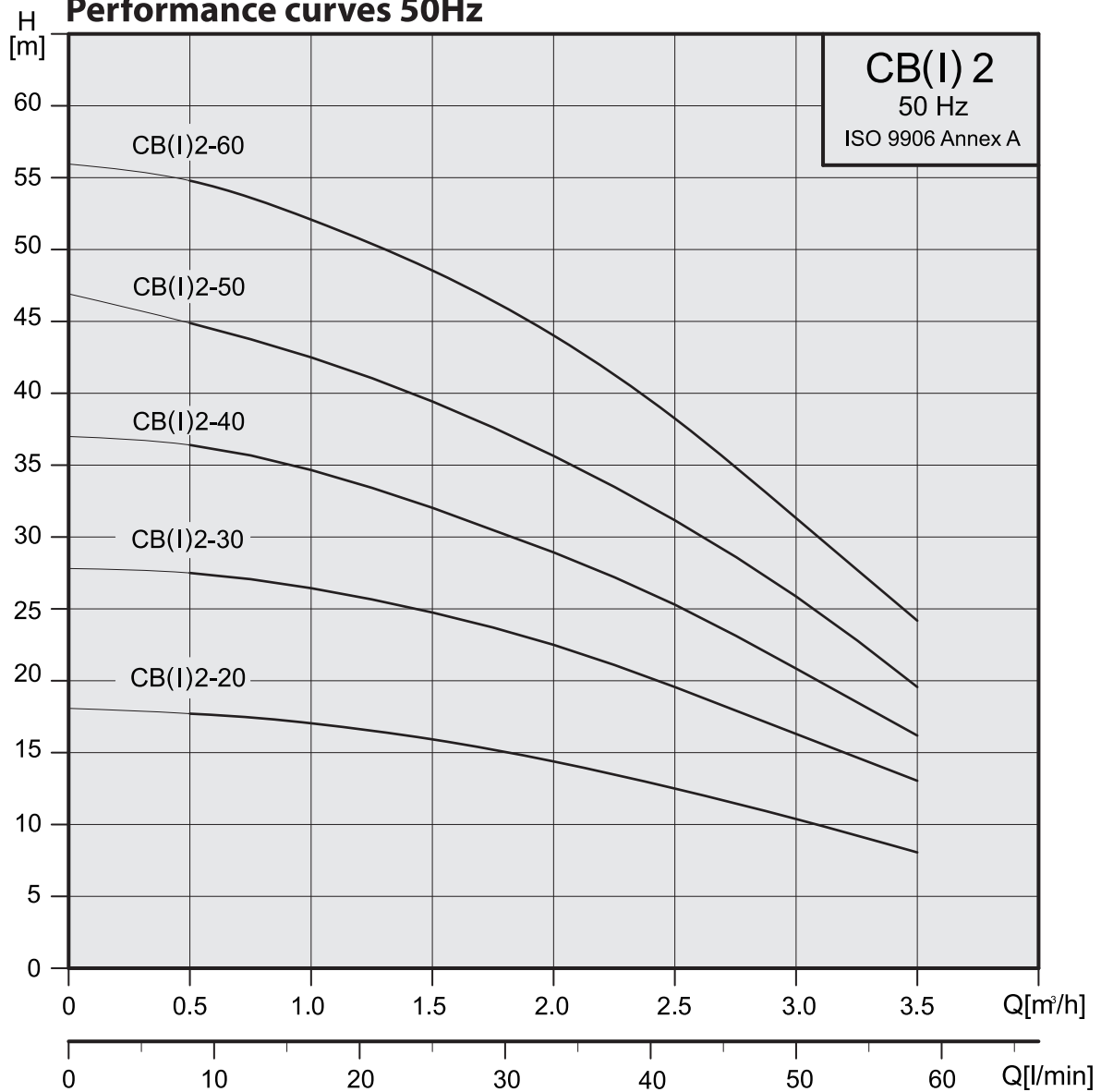

## Electrical data, 2850 rpm

Pump type	1Φ 220-240V			3Φ Δ220-240V / Y 380-415V		
	I <sub>1n</sub> [A]	P <sub>1</sub> [W]	P <sub>2</sub> [W]	I <sub>1n</sub> [A]	P <sub>1</sub> [W]	P <sub>2</sub> [W]
CB/CBI 2-20	1.7 - 2.0	380	295	2.2 - 2.6 / 1.3 - 1.5	430	330
CB/CBI 2-30	2.1 - 2.2	470	360	2.2 - 2.5 / 1.3 - 1.45	530	410
CB/CBI 2-40	2.7 - 2.8	620	480	2.4 - 2.8 / 1.4 - 1.6	660	510
CB/CBI 2-50	3.2 - 3.1	720	550	2.5 - 2.9 / 1.45- 1.7	770	585
CB/CBI 2-60	3.7 - 3.6	830	630	2.9 - 3.3 / 1.7 - 1.9	860	655



STAIRS PUMPS

# Technical data

CB, CBI 4

## Performance curves 50Hz

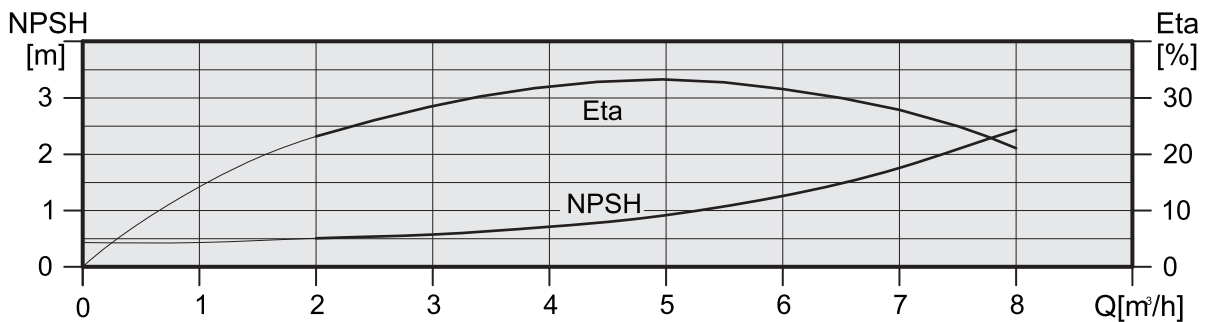
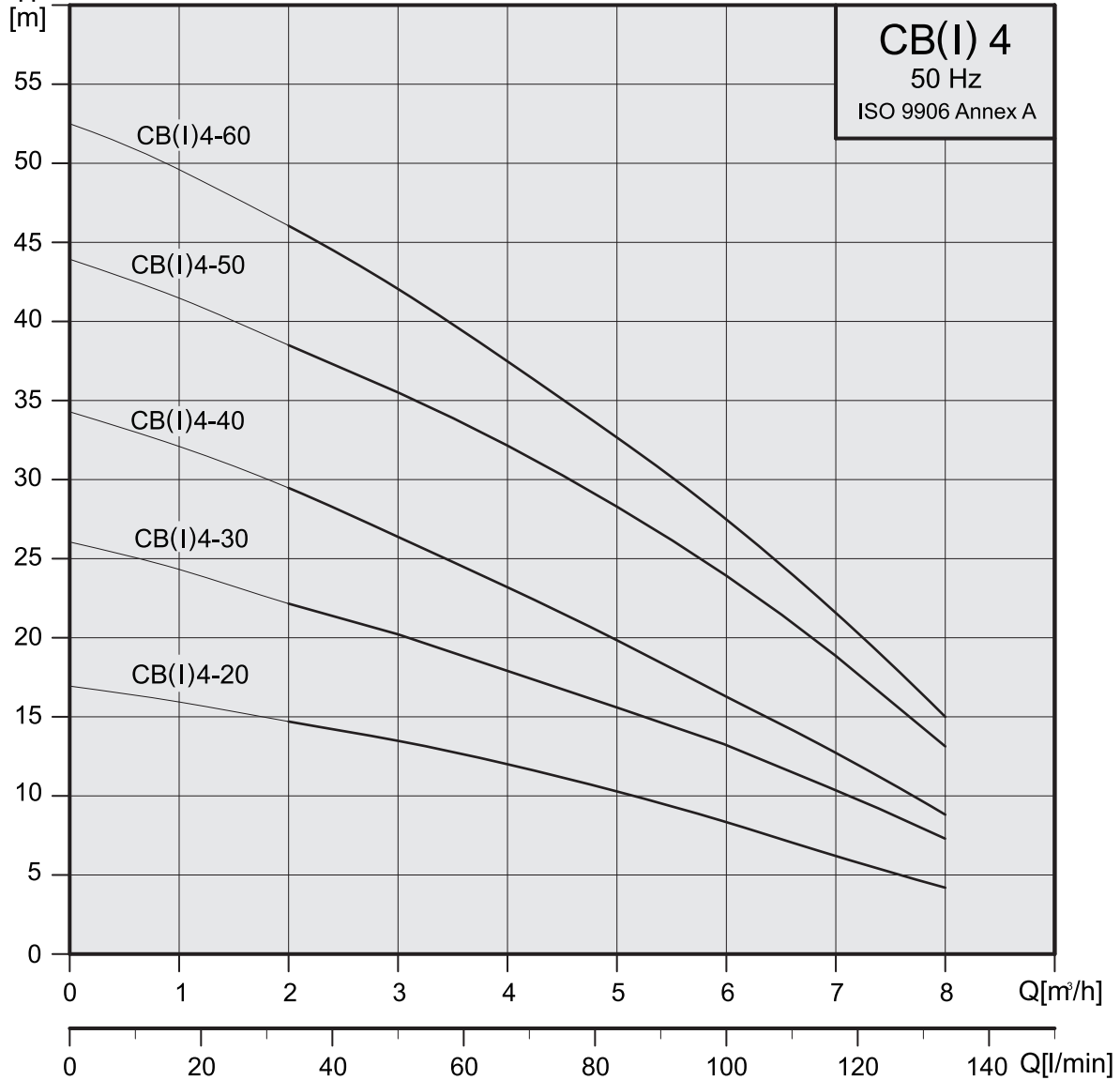

## Electrical data, 2850 rpm

Pump type	1Φ 220-240V			3Φ Δ220-240V / Y 380-415V		
	I <sub>1/1</sub> [A]	P <sub>1</sub> [W]	P <sub>2</sub> [W]	I <sub>1/1</sub> [A]	P <sub>1</sub> [W]	P <sub>2</sub> [W]
CB/CBI 4-20	2.6 - 2.5	560	430	2.4 - 2.9 / 1.4 - 1.7	610	465
CB/CBI 4-30	3.6 - 3.5	770	595	2.5 - 2.9 / 1.5 - 1.7	790	604
CB/CBI 4-40	4.4 - 4.1	960	735	3.1 - 3.3 / 1.8 - 1.9	1010	770
CB/CBI 4-50	5.3 - 5.0	1160	940	4.2 - 4.5 / 2.4 - 2.6	1240	990
CB/CBI 4-60	6.7 - 6.4	1430	1135	5.1 - 5.5 / 2.9 - 3.2	1460	1180



STAIRS PUMPS

# Technical data

CB, CBI

## Dimensions and weights 50 Hz

### CB-2, CB-4

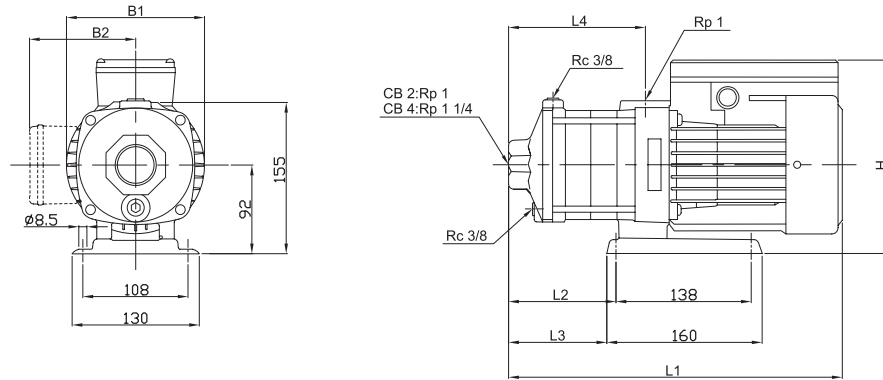

pump type	mm									Kg	
	L1	L2	L3	L4	B1	B2		H		1phase	3phase
						1phase	3phase	1phase	3phase		
CB 2-20	309	75	63	101	141	127	115	228	207	10.3	10.0
CB 2-30	327	93	81	119	141	127	115	228	207	10.5	10.3
CB 2-40	345	111	99	137	141	127	115	228	207	10.8	10.5
CB 2-50	363	129	117	155	141	127	115	228	207	11.6	11.2
CB 2-60	381	147	135	173	141	127	115	228	207	11.8	11.5
CB 4-20	318	84	72	110	141	127	115	228	207	10.4	10.1
CB 4-30	344	111	99	137	141	127	115	228	207	10.8	10.5
CB 4-40	372	138	126	164	141	127	115	228	207	11.6	11.2
CB 4-50	438	165	153	191	141	127	115	228	207	13.4	13.1
CB 4-60	465	192	180	218	141	127	115	228	207	14.8	14.5

### CBI-2, CBI-4

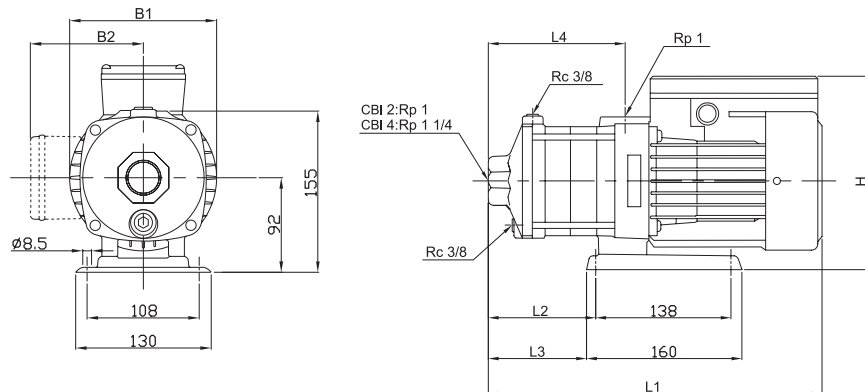

pump type	mm									Kg	
	L1	L2	L3	L4	B1	B2		H		1phase	3phase
						1phase	3phase	1phase	3phase		
CBI 2-20	309	75	63	101	141	127	115	228	207	9.1	8.8
CBI 2-30	327	93	81	119	141	127	115	228	207	9.4	9.1
CBI 2-40	345	111	99	137	141	127	115	228	207	9.6	9.4
CBI 2-50	363	129	117	155	141	127	115	228	207	10.4	10.1
CBI 2-60	381	147	135	173	141	127	115	228	207	10.7	10.3
CBI 4-20	318	84	72	110	141	127	115	228	207	9.2	9.0
CBI 4-30	344	111	99	137	141	127	115	228	207	9.6	9.3
CBI 4-40	372	138	126	164	141	127	115	228	207	10.4	10.1
CBI 4-50	438	165	153	191	141	127	115	228	207	11.3	12.0
CBI 4-60	465	192	180	218	141	127	115	228	207	13.6	13.4



STAIRS PUMPS

# Technical data

## CB 8

### Performance curves 50Hz

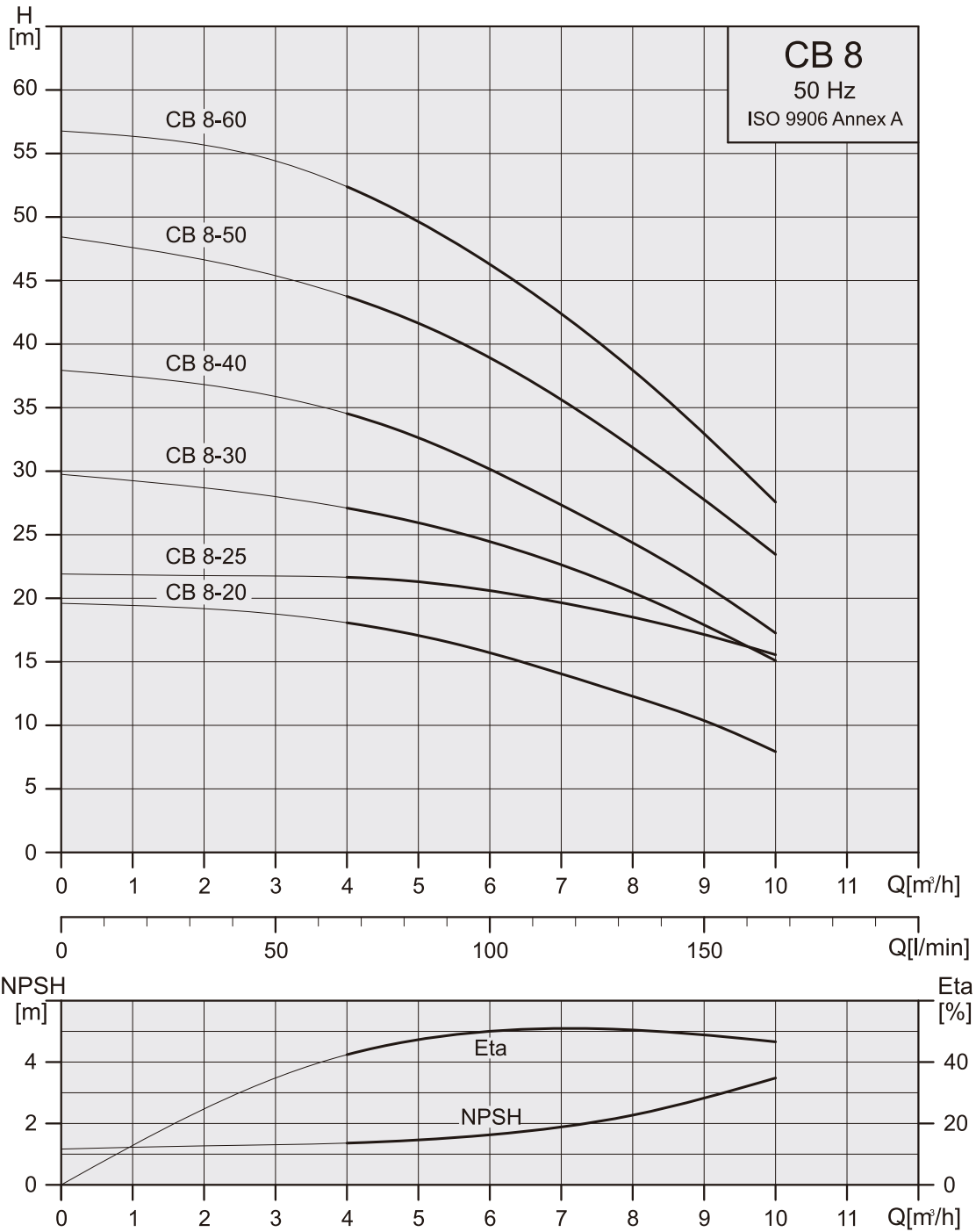

### Electrical data, 2850 rpm

Pump type	1Φ 220-240V			3Φ Δ220-240V / Y 380-415V		
	I <sub>1n</sub> [A]	P <sub>1</sub> [W]	P <sub>2</sub> [W]	I <sub>1n</sub> [A]	P <sub>1</sub> [W]	P <sub>2</sub> [W]
CB 8-20	3.3 - 3.2	760	595	2.9 - 3.3 / 1.7 - 1.9	810	620
CB 8-25	—	—	—	3.5 - 3.8 / 2.0 - 2.2	1060	860
CB 8-30	5.2 - 5.0	1130	910	4.3 - 4.8 / 2.5 - 2.8	1260	1020
CB 8-40	6.3 - 6.1	1390	1105	5.7 - 6.3 / 3.3 - 3.7	1520	1205
CB 8-50	8.2 - 8.1	1940	1610	5.7 - 6.3 / 3.4 - 3.7	1860	1475
CB 8-60	9.0 - 8.8	2090	1740	6.5 - 7.0 / 3.8 - 4.1	2110	1755



STAIRS PUMPS

# Technical data

CB 12

## Performance curves 50Hz

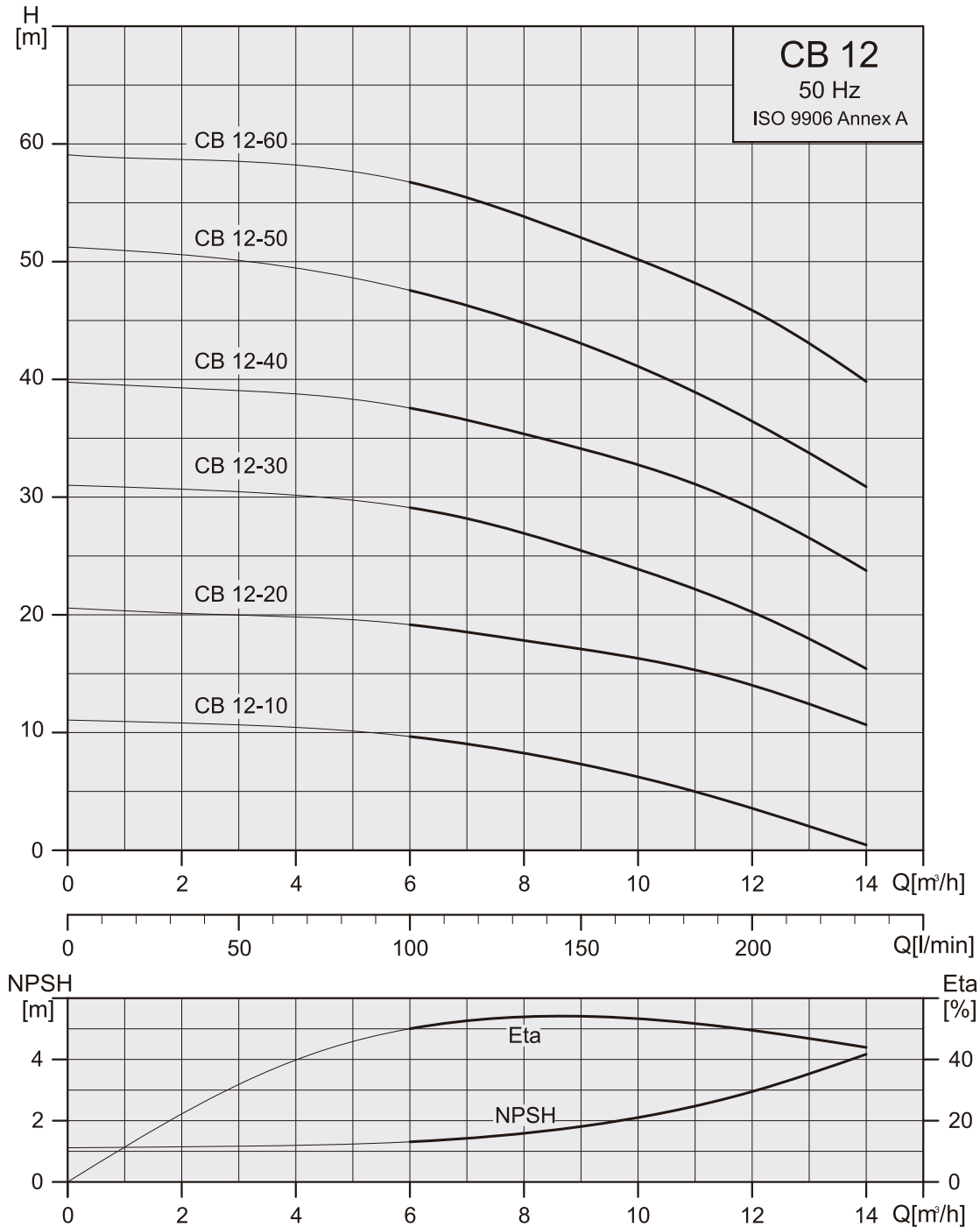

## Electrical data, 2850 rpm

Pump type	1Φ 220-240V			3Φ Δ220-240V / Y 380-415V		
	I <sub>1n</sub> [A]	P <sub>1</sub> [W]	P <sub>2</sub> [W]	I <sub>1n</sub> [A]	P <sub>1</sub> [W]	P <sub>2</sub> [W]
CB 12-10	—	—	—	2.8 - 3.1 / 1.6 - 1.8	590	455
CB 12-20	5.3 - 5.1	1160	935	3.8 - 4.0 / 2.2 - 2.3	1170	950
CB 12-30	7.8 - 7.4	1680	1330	5.7 - 6.5 / 3.3 - 3.8	1690	1365
CB 12-40	11.0 - 10.6	2400	1995	7.3 - 7.6 / 4.2 - 4.4	2350	1960
CB 12-50	12.7 - 12.2	2910	2440	8.8 - 9.0 / 5.1 - 5.2	2820	2375
CB 12-60	—	—	—	10.6-11.4 / 6.1 - 6.6	3320	2860



STAIRS PUMPS

# Technical data

CB

## Dimensions and weights 50 Hz

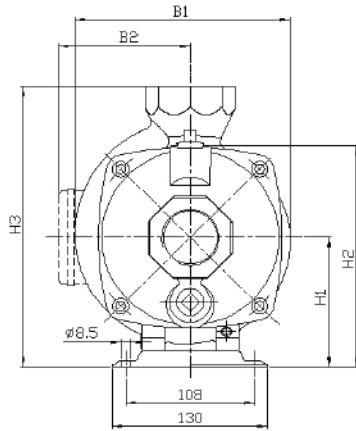

Fig. 1

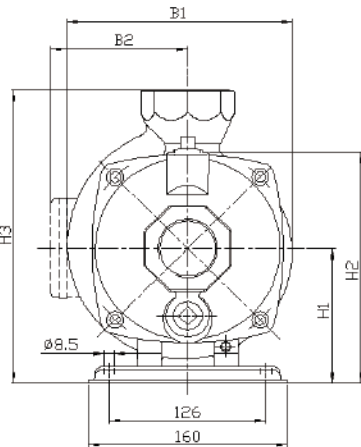
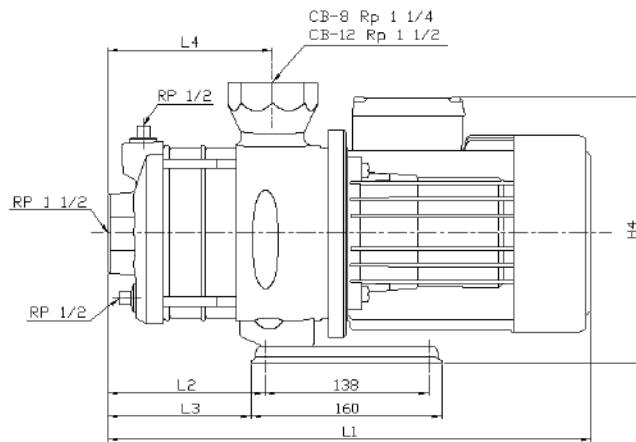
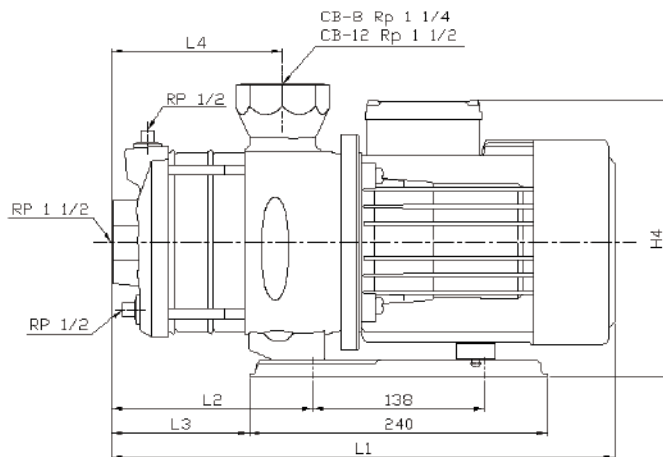

Fig. 2



### CB - 8

Pump type	Dimension [ mm ]																				Fig.		Net Weight [ mm ]	
	1 phase										3 phase										1Φ	3Φ	1Φ	3Φ
	L1	L2	L3	L4	B1	B2	H1	H2	H3	H4	L1	L2	L3	L4	B1	B2	H1	H2	H3	H4				
CB 8-20	320	54	41	77	181	135	110	187	239	245	320	54	41	77	181	114	110	187	239	224	1	1	17.2	17.0
CB 8-25	-	-	-	107	-	-	110	187	239	-	390	84	71	107	181	114	110	187	239	224	-	1	-	19.1
CB 8-30	390	84	71	107	181	135	110	187	239	245	390	84	71	107	181	114	110	187	239	224	1	1	19.5	19.2
CB 8-40	390	84	71	107	181	135	110	187	239	245	390	84	71	107	181	114	110	187	239	224	1	1	20.7	20.5
CB 8-50	480	162	111	137	185	152	110	187	239	262	420	114	101	137	181	114	110	187	239	224	2	1	28.5	21.4
CB 8-60	480	162	111	137	185	152	110	187	239	262	480	162	111	137	185	139	110	187	239	249	2	2	28.7	27.6

### CB - 12

Pump type	Dimension [ mm ]																				Fig.		Net Weight [ mm ]	
	1 phase										3 phase										1Φ	3Φ	1Φ	3Φ
	L1	L2	L3	L4	B1	B2	H1	H2	H3	H4	L1	L2	L3	L4	B1	B2	H1	H2	H3	H4				
CB 12-10	-	-	-	77	-	-	110	187	239	-	320	54	41	77	181	114	110	187	239	224	-	1	-	17.9
CB 12-20	360	54	41	77	181	135	110	187	239	245	360	54	41	77	181	114	110	187	239	224	1	1	18.4	18.2
CB 12-30	390	84	71	107	181	135	110	187	239	245	390	84	71	107	181	114	110	187	239	224	1	1	20.6	20.4
CB 12-40	450	132	81	107	185	152	110	187	239	262	450	132	81	107	185	139	110	187	239	249	2	2	27.7	26.7
CB 12-50	480	162	111	137	185	152	110	187	239	262	480	162	111	137	185	139	110	187	239	249	2	2	29.8	29.9
CB 12-60	-	-	-	137	-	-	122	199	251	-	501	162	111	137	196	150	122	199	251	272	-	2	-	35.2