

General Data/Material



Operating Conditions	Applications	Emptying of septic tanks and residential sumps.
	Fluid Temperature	0 to 50 °C
Motor	Type	Dry Type
	Pole	2-pole
	Insulation	Class F
	Protection	IP68
	Protection Device	Thermal Protector (single phase)
Pump	Impeller	Open Impeller
	Shaft Seal/Material	Double seals
	Bearing	Double-shielded Ball Bearing

Component	Material
Cable	H07RN-F
Handle	AISI 304+Nylon
Motor Cover	AISI 304
Motor Casing	AISI 304
Fixing Ring	AISI 304
Pump Body	AISI 304
Mechanical seal	Sic/Sic/NBR
Impeller	AISI 304
Key	AISI 304
Pump Casing	AISI 304
Oil Seal	NBR
Shaft	AISI 304
V-type Axial Oil Seal	NBR
Suction flange	AISI 304

Characteristic curves N= 2900 rpm

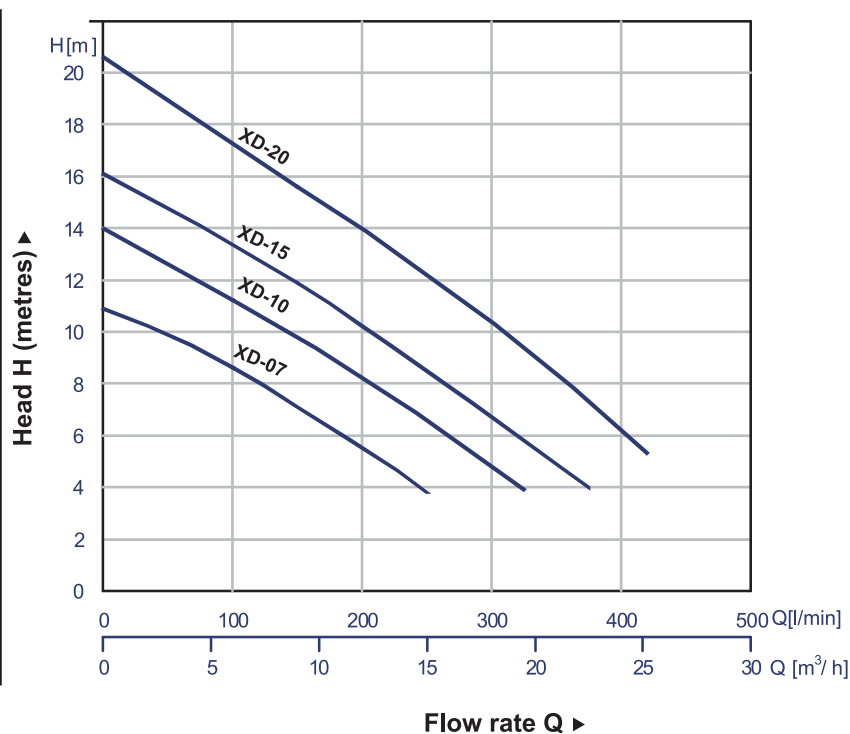

Specifications

Model	Power HP (kW)	Discharge inch	Phase	Standard		Max		Solid Passage mm	Cable M
				Head M	Capacity LPM	Head M	Capacity LPM		
XD-07	0.75(0.55)	RP 1 1/2"	1 ϕ /3 ϕ	8.6	100	10.9	250	8	10
XD-10	1.0(0.75)	RP 1 1/2"	1 ϕ /3 ϕ	11.2	100	14	325	8	10
XD-15	1.5(1.1)	RP 1 1/2"	1 ϕ /3 ϕ	11.9	150	16.1	375	8	10
XD-20	2.0(1.5)	RP 1 1/2"	3 ϕ	15.6	150	20.6	420	8	10

Auto Float Switches are available in Single-phase

Dimensions and Weights

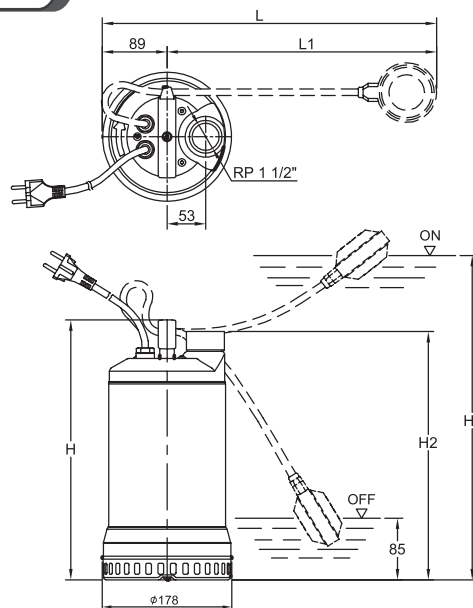

SINGLE-PHASE

Model	Dimension (mm)					
	H	H1	H2	L	L1	N.W. kg
XD-07	357	437	341	459	370	12
XD-10	407	497	391	514	425	15
XD-15	407	497	391	514	425	17

THREE-PHASE

Model	Dimension (mm)		
	H	H2	N.W. kg
XD-07	357	341	12
XD-10	357	341	12
XD-15	407	391	15
XD-20	407	391	17